



**ST. MORITZ EDITION**

---

# **COPPA DELLE ALPI**

*by 1000 Miglia*

COPPA DELLE ALPI BY 1000 MIGLIA 2026

St. Moritz, from 12 to 14 March 2026

SUPPLEMENTARY REGULATIONS

(S.R.)

ORGANISATION: 1000 Miglia S.r.l.

## REGOLAMENTO PARTICOLARE DI GARA (RPG)

# EPOCA CHAMPIONSHIP®

Campionato Italiano Grandi Eventi Aci Sport

## PROGRAMME

### PROGRAMME BEFORE THE COMPETITION WEEK

<b>Wednesday 29 October 2025</b>		
Date of publication of SR		Website
Opening date for entries		Competition Secretary
<b>Tuesday 17 February 2026 at 16:00</b>		
Closing Date for entries		Competition Secretary
Deadline for communication of crews belonging to a "Sponsor Team"		Competition Secretary
<b>by Friday 20 February 2026</b>		
Communication to entrants of their acceptance		Competition Secretary
Publication of list of Competitors and cars accepted (After this date, it will no longer be possible to replace competitors, crews and registered cars)		Website
Deadline for sending of graphics for a Sponsor Team sticker		Competition Secretary
<b>By Friday 6 March 2026</b>		
Deadline for the refund of deposit payment from competitors who have not been accepted and who were not on the waiting list		Competition Secretary

### PROGRAMME FOR THE COMPETITION WEEK

<b>Administrative checks</b>	Place	St. Moritz,...TBA...		
	Date	12/03/2026	time	...TBD....
<b>Distribution of the Road Book and race numbers</b>	Place	St. Moritz,...TBA...		
	Date	12/03/2026	time	...TBD....
<b>Pre-race Technical Scrutineering</b>	Place	St. Moritz,...TBA...		
	Date	12/03/2026	time	...TBD....
<b>Post-race Technical Scrutineering</b>	Place	St. Moritz,...TBA...		
	Date	14/03/2026	time	by 18:00
<b>Briefing of the Clerk of the Course</b> (Papers distributed at the Pre-race Checks)	Place	St. Moritz,...TBA...		
	Date	12/03/2025	time	...TBA...
<b>Publication of the start list</b> "Coppa delle Alpi 2026"	Place	Website -Official Notice Board		
	Date	12/03/2026	time	within 15:00

## Coppa delle Alpi by 1000 Miglia 2026 | Supplementary Regulations

Start leg 1	Place	St. Moritz, Via Maistra	Date	12/03/2026	time	15:30
Arrival leg 1	Place	St. Moritz, Piazza del Comune	Date	12/03/2026	time	17:00
Start leg 2	Place	St. Moritz, Via Maistra	Date	13/03/2026	time	08:15
Arrival leg 2	Place	St. Moritz, Via Traunter Plazzas	Date	13/03/2026	time	17:30
Start leg 3	Place	St. Moritz, Via Maistra	Date	14/03/2026	time	08:30
Arrival leg 3	Place	St. Moritz, Via Maistra	Date	14/03/2026	time	17:45
Publication of the Final Classification	Place	Official Notice Board - Website	Date	14/03/2026	time	19:00 (estimated time)
Prize Giving	Place	St. Moritz, ...TBD...	Date	14/03/2026	time	...TBD...
<b>Competition headquarters - Official Notice Board</b>						
	Place	St. Moritz, ...TBD...	Date	from 12/03/2026 to 14/03/2026	time	...TBD...
<b>Competition Secretary - Official Notice Board</b>						
	Place	St. Moritz, ...TBD...	Date	from 12/03/2026 to 14/03/2026	time	...TBD...
Official Notice Board (ONB):	App Sportity					
App SPORTITY password:	CDAMM2026					

---

Synchronization of the Organisation's time-keeping systems: UTC (GPS) signal | Italia: GMT+1

---

### INTERPRETATION

All the times states in these SR are understood as referring to the Time Zone in use in Italy, namely "Greenwich Mean Time + 1 hour" conventionally UTC (GPS) signal | Italy: GMT+1

The acronym "ASN" stands for National Sport Authority (ACI Sport).

Value Added Tax (VAT) will be applied on all amounts stated in these SR at a rate of 22% (updated to 13.10.2025). Any variation on this percentage will be notified in the Bulletin and will be enforced in compliance with the laws issued by Italy.

**TO ALL LEGAL EFFECTS, THE ITALIAN VERSION OF THESE SR WILL BE BINDING. THE ENGLISH TRANSLATION OF THE SAME IS UNDERSTOOD AS BEING SOLELY FOR INFORMATION PURPOSES.**

# Coppa delle Alpi by 1000 Miglia 2026 | Supplementary Regulations

## Article 1 - ORGANISATION

This event will be run in compliance with the International Sport Code (and relevant appendixes, where applicable), with the National Sport Regulations (and relevant appendixes where applicable) and with other provisions of the ACI Sport, which are understood to regulate whatever is not indicated in the following articles.

The Organiser states that the competition will have all the necessary administrative authorisations and the required insurance coverage.

## Article 2 - OFFICIALS

Clerk of the course:	<b>Mr. Lucio DE MORI</b>	licence n. <b>20623</b>
Sporting Stewards	-----TBA-----	licence -----
Sporting Scrutineers	<b>Elena CHIARI</b> <b>Claudia MELONI</b>	licence n. <b>490146</b> licence n. <b>490158</b>
Technical Scrutineers:	-----TBA----- -----TBA----- -----TBA-----	licence ----- licence ----- licence -----
First meeting of the Sporting Stewards	Place <b>St. Moritz, ...TBA...</b> Date <b>12/03/2026</b>	time <b>...TBD...</b>
Sporting secretary of the event	-----TBA-----	licence -----
Marshals:	<b>of the Automobile Club of Brescia</b>	
Time keeping Service:	<b>F.I.Cr. (Federazione Italiana Cronometristi)</b>	
Head of Timing Service:	-----TBA-----	
Results:	-----TBA-----	
Competitor Relations Officers	-----TBA-----	licence -----
Doctor:	-----TBA-----	licence -----
Press Officer:	<b>Fulvia LODA GELMINI</b>	

## Article 3 - RACE

The Organiser 1000 MIGLIA SRL holder of the licence n. 356540, announces and organises, from 12 to 14 March 2026 a Classic Regularity Competition for Historical Cars, Grand Event, to be known as:

# COPPA DELLE ALPI BY 1000 MIGLIA 2026

The race belongs to zone //.

The race will be held over 3 days.

## Article 4 - COMPETITORS, DRIVERS AND CARS ALLOWED

### 4.1 COMPETITORS AND DRIVERS ALLOWED

**4.1.1** Competitors, and crew members must hold a valid ACI Sport Competitor/Driver's Licence or a valid regularity licence (for Italian competitors/Drivers) or a valid Co-driver or Competitor/Driver's licence, issued by their ASN

(for foreign competitors/drivers of International or National - with authorisation to compete in the event - level) valid in Italy.

- 4.1.2 At least one of the two crew members must be in possession of a valid driving licence during all the legs of the race. Crew members without an Italian driving licence, or in any case valid in Italy, must also present, if necessary, an international driving licence, valid in Italy
- 4.1.3 A competitor will be able to register, for each car, a crew composed of a maximum of two people who will be the only ones to stay on board the car during race.
- 4.1.4 A competitor who is a physical entity, entering a vehicle for the competition must always be on board the vehicle throughout the race. In the case of a Competitor being a legal person, he/she may enter more than one car and appoint a Crew for each one, but it is expressly forbidden to exchange Crews between the entered cars.
- 4.1.5 During all the phases of the competition the vehicle may be driven only by crew members who have been verified and accepted with that specific vehicle.
- 4.1.6 Crew members below the age of 14 (i.e. those who have not yet turned 14 at the date of the end of the checks) and older than 85 years of age (i.e. those who will have already turned 86 as of 15.03.2025) will not be accepted.
- 4.1.7 Passengers will not be allowed, that is, crew members who have not been verified and who are not in possession of the requirements of Article 4.1.1, 4.1.2 and 4.1.6 of these SR.

### 4.1.8 DOCUMENTATION REQUIRED IN ORDER TO OBTAIN A SPORTS LICENCE

The maximum age for obtaining the regularity licence, whether daily for foreigners or annual for Italians, is 85 years for both sexes. Below is the list of the documentation necessary for obtaining the prescribed licence:

**a) Drivers of Italian nationality UNDER 85 at the date of the closure of the race**

In order to issue/renew the licence, the following documents are required:

- medical certificate for non-competitive sports activities (Facsimile in Appendix 1 to these SR) obtained in Italy as per current regulations;
- driving licence (only for drivers);
- ACI membership card (for those not in good standing with the association, it will be possible to renew/issue this on-site by communicating the data of the car used every day, or the licence plate number of the historic car entered in the race, depending on the type of ACI Service required).

**b) Co-drivers (not permitted to drive the car) of Italian nationality UNDER 85 at the date of the end of the race**

In order to issue/renew the licence, the following documents are required:

- medical certificate for non-competitive sports activities (Facsimile in Appendix 1 to these SR) obtained in Italy as per current regulations;
- ACI membership card (for those not in good standing with the association, it will be possible to renew/issue this on-site by communicating the data of the car used every day, or the licence plate number of the historic car entered in the race, depending on the type of ACI Service required).

**c) Drivers not of Italian nationality UNDER 85 at the date of the end of the race**

In order to issue/renew the licence, the following documents are required:

- medical certificate for non-competitive sports activities (Facsimile in Appendix 1 to these SR) obtained in Italy as per current regulations; alternatively, a medical certificate of good health issued abroad, written in English, signed and stamped by a doctor.
- self-certification stating you do not hold other valid licences issued by other ASN and to not having incurred disciplinary sanctions;
- national and international driving licence (for drivers and co-drivers).

**d) Co-drivers (not permitted to drive the car) not of Italian nationality OVER 85 at the date of the end of the race**

In order to issue/renew the licence, the following documents are required:

- medical certificate for competitive sports activities (Facsimile in Appendix 2 to these SR) obtained in Italy as per current regulations; alternatively, a medical certificate of good health issued abroad, written in English, signed and stamped by a doctor.
- self-certification to not possessing other valid licences issued by other ASN and to not having incurred disciplinary sanctions.

## 4.2 SPONSOR - SPONSOR TEAM

### 4.2.1 "SPONSOR"

The Sponsors of Coppa delle Alpi 2026 who are entitled, by contract, will be able to:

- a) create a "Sponsor Team" made up of the vehicles indicated in their own quota as per the sponsorship contract (article 4.2.2 of these SR);

### 4.2.2 "SPONSOR TEAM"

Over and above what is stated in Article 4.2.1 in these SR, the Sponsors who request it will have the opportunity to create a "Sponsor Team" and enjoy the following conditions:

- a) the use of an additional advertising space (adhesive) on the sides of the competition car (Article 13.3 in these SR) for each car that is part of the "Sponsor Team";

"Sponsor Teams" are not comparable to the racing teams.

## 4.3 ACCEPTED CARS

A maximum of 60 cars will be admitted to the competition.  
Cars with a "test" number plate are not allowed.

### 4.3.1 The cars must also belong to the following classification periods:

- |   |       |                       |
|---|-------|-----------------------|
| A | built | from Origins to 1904; |
| B | built | from 1905 to 1918;    |
| C | built | from 1919 to 1930;    |
| D | built | from 1931 to 1946;    |
| E | built | from 1947 to 1961;    |
| F | built | from 1962 to 1965;    |

Each car must be included in each period based on the actual year of construction.

### 4.3.2 The cars belonging to the following classification periods could be admitted to the race but they cannot compete for the awarding of the titles of the Italian Major Events Regularity Championship (Drivers, Category, Teams) and of the National Class Trophies:

- |    |       |                    |
|----|-------|--------------------|
| G  | built | from 1966 to 1971; |
| H  | built | from 1972 to 1976; |
| I  | built | from 1977 to 1981; |
| J1 | built | from 1982 to 1987; |
| J2 | built | from 1988 to 1992; |
| K  | built | from 1993 to 2000. |

Cars belonging to the periods G, H, I, J1, J2, K will form the Coppa delle Alpi Classic group.

### 4.3.3 The cars allowed will be divided into the following Categories:

- Group RC1 cars belonging to the Periods: A, B, C (built until 1930)

## Coppa delle Alpi by 1000 Miglia 2026 | Supplementary Regulations

- Group RC2 cars belonging to the Periods: D, E (built from 1931 to 1950)
- Group RC3 cars belonging to the Periods: E, F (built from 1951 to 1965)
- Group RC4 cars belonging to the Periods: G, H, I (built from 1966 to 1981)
- Group RC5 cars belonging to the Periods: J1, J2 (built from 1982 to 1992)
- Group RC6 cars belonging to the Periods: K (built from 1993 to 2000)

4.3.4 Within each category, the admitted cars will be divided into the following cubic capacity CLASSES:

- 1) Up to 1.600 cc
- 2) From 1.601 to 2.000 cc
- 3) Over 2.000 cc

Up to 35 modern cars may be admitted as accompanying vehicles.

### 4.3.5 SELECTION OF REGISTERED CARS

Cars built up to 31/12/1965 will not be subject to selection by the Organizer and will be accepted in the manner prescribed by current regulations being guaranteed acceptance in compliance with the maximum number of 60 admissible cars.

Cars built starting from 01/01/1966 will be subject to selection by the Organizer.

4.3.6 The cars entered must comply with the periodic revision of the vehicles if required and in accordance with the provisions of the laws of the country of registration. If the country of registration does not provide for the periodic revision of the cars, the competitor must produce a self-declaration in which he must declare the lack of need for revision according to the laws of the country of registration and consequently, he will declare to be able to circulate in his own country of origin having undergone all the technical checks to demonstrate the perfect efficiency of the car and all its devices. In the absence of this document the crew will not be able to pass the administrative checks.

### 4.4 RACE NUMBERS – ENTRY LIST

Subject to specific organisational requirements, the allocation of race numbers, also valid for the drawing up of the Starting Order, will respect the priority levels of the drivers and, within each level, according to the seniority of the car, with priority given to the oldest cars.

## Article 5 - ROUTE

5.1 The competition route will have an overall length of Km 645,00 and will be described in the Itinerary Table (TDT) attached to these SR, and of which it is an integral part, and in the Road Book. The TDT will also show the methods of carrying out the timed Legs for classification.

There will be 90 Time Trials (PC/TT), 8 Average Trials (PM/AT), 10 Time Controls (CO/TC) and 4 Passage Controls (CT/PC).

The start will be in St. Moritz (CH), Via Maistra at 15:30 on 12/03/2026 and the arrival will be in St. Moritz (CH), Via Maistra, as from 17:45 on 14/03/2026.

The competition will take place on roads open to traffic, barring any limitations set by the competent Administration Authorities, with average speeds not exceeding 40 Km/h.

### 5.2 POWER STAGE

During the Coppa delle Alpi by 1000 Miglia 2026, a Power Stage will be held, awarding extra points for the championship. Participation in the Power Stage is mandatory for all competitors registered in the event and will consist of three timed sections measured to the hundredth of a second (referred to as SPLIT 1-2-3), connected in sequence.

The penalties incurred in the three timed sections will not be included in the total penalties accumulated by competitors during the main race.

The regulations and procedures for the Power Stage will be communicated to all competitors through a bulletin.

### Article 6 – ENTRIES

#### 6.1 APPLICATION FORM

By signing the entry application form, the Competitor and Drivers undertake to submit only to the sporting jurisdictions recognised by the International Sporting Code and to the provisions of these SR.

Presentation of the entry form does not give the right to participate in the race as the organiser will select the requests and accept entries in his unquestionable judgement.

The organisers will not be required to motivate the reason for exclusion, nor will the said exclusion allow for the request for damages and/or refund of expenses, excepting for the return of the deposit (Art. 6.3 of these SR).

#### 6.2 METHOD OF PRESENTATION OF THE APPLICATION FORM

Entry applications may only be submitted via the Website [www.1000Miglia.it](http://www.1000Miglia.it).

The presentation date of each competitor's entry application coincides with the date on which the sum provided for in art. 6.3 below is credited to the bank account in the name of the Organiser. Entry must be formalized according to the days and times indicated in the Programme of these SRR.

Acceptance of the entry application will be announced to the Competitor according to the terms and conditions set out in these SRR.

#### 6.3 ENTRY GUARANTEE DEPOSIT

6.3.1 Payment of the amounts specified below, depending on the selected service package, valid as a deposit for entry of the car and team must be made in one of the following ways:

- a) by Credit Card (only VISA - MASTERCARD) by 16:00 (GMT+1) on Tuesday 17 February 2026.
- b) by bank transfer to the coordinates indicated in the entry form, with maximum credit value on the 1000 Miglia S.r.l. current account by 16:00 (GMT+1) on Tuesday 17 February 2026.

#### 6.4 REQUEST TO ENTRY OF A "SPONSOR TEAM"

In order to inform the Organizer of the willingness of a sponsor entitled to exercise the "Sponsor Team" option, the specific application form signed by the legal representative of the Sponsor must be sent, confirmed by email by the Competitors of the identified cars, no later than 16:00 p.m. (GMT+1) on Tuesday 17 February 2026, to [participants@1000miglia.it](mailto:participants@1000miglia.it) with a request for acceptance by the receiver and followed by confirmation of receipt by the receiver.

Competitors with certified electronic mail (PEC) must send the abovementioned notice to the PEC address: [1000miglia@legalmail.it](mailto:1000miglia@legalmail.it)

#### 6.5 ACCEPTABILITY OF ENTRY REQUESTS

Entry requests must be complete with all the necessary documentation, also photographic, accompanied by the greatest number of documents attesting the history of the registered vehicle, and the payment of the deposit.

Failure to pay the deposit means the request for entry will not be taken into consideration.

Requests which are untrue, incomplete, without documentation or with amounts owing to the organisation, will not be taken into consideration.

The organisation reserves the right not to accept vehicles whose drivers have been penalised in previous editions of the "1000 Miglia".

The organizer also reserves the right not to accept the entry of drivers who for three times during the previous year's

race committed infractions of exceeding the speed limit set by the authorities in charge and detected by the Speed Test prepared by the Management Race.

## 6.6 ACCEPTANCE OF ENTRY

By Friday 20 February 2026, each team will be able to verify online, inside its own reserved area, whether or not the entry for the competition has been accepted. Confirmation will nonetheless be sent also to the e-mail address indicated in the relative area of the entry form.

To complete entry it will be necessary to enter the Bank details in the relative section of the on-line form, for the return of the fee, if necessary.

### 6.6.1 FINALISING ENTRY

Entry is understood as being finalised only on acceptance of the entry request by the organiser and to the allocation of the sum paid as a deposit in the sum paid as an entry fee.

After the car has been accepted at the event, 1000 Miglia Srl will issue a regular invoice, using the data requested during the entry phase.

By presenting the request for entry, the applicant authorises the organiser to consider the amount paid previously as a deposit, as an entry fee in the case of acceptance of the request for entry.

## 6.7. ENTRY FEE

The following entry fees are envisaged:

### 6.7.1 BASIC ENTRY:

The Basic entry fee amounts to € 6.500,00 plus 22% VAT - total € 7.930,00 (if the registration is completed by December 22, the amount due is € 5,900.00 plus 22% VAT – total € 7,198.00 VAT included) and includes:

- a) Participation in the competition after selection of the car:
  - kits of documents and technical materials required;
  - Official Merchandising;
  - Standard Pass.
- b) Hospitality for a crew of two persons, including:
  - 3 nights in a double room in Hotel 4\* stars with breakfast - IN 12 March 2026, OUT 15 March 2026;
  - 3 light buffet lunch per person;
  - 2 light dinner per person;
  - Prize ceremony.
- c) Services included in the entry:
  - Possibility to purchase additional service packages.

### 6.7.2 BASIC PLUS ENTRY:

The Basic Plus entry fee amounts to € 8.000,00 plus 22% VAT - total € 9.760,00 - if the registration is completed by December 22, the amount due is € 7,400.00 plus 22% VAT – total € 9,028.00 VAT included) and includes:

- a) Participation in the competition after selection of the car:
  - kits of documents and technical materials required;
  - Official Merchandising;
  - Standard Pass.
- b) Hospitality for a crew of two persons, including:
  - 3 nights in two single room in Hotel 4\* stars with breakfast - IN 12 March 2026, OUT 15 March 2026;
  - 3 light buffet lunch per person;

- 2 light dinner per person;
  - Prize ceremony.
- c) Services included in the entry:
- Possibility to purchase additional service packages.

### 6.7.3 GOLD ENTRY

The Gold entry fee amounts to € 9.000,00 plus 22% VAT - total € 10.980,00 (if the registration is completed by December 22, the amount due is € 8,400.00 plus 22% VAT – total € 10,248.00 VAT included) - and includes:

- a) Participation in the competition after selection of the car:
- kits of documents and technical materials required;
  - Official Merchandising;
  - “Gold” Pass.
- b) Hospitality for a crew of two persons, including:
- 3 nights in double room in Hotel 5\* Stars, with breakfast - IN 12 March 2026, OUT 15 March 2026;
  - 3 Light Lunch a buffet per person;
  - 2 Light Dinner per person;
  - Prize Ceremony.
- c) Services included in the entry:
- Possibility to purchase additional service packages.

### 6.7.4 GOLD PLUS ENTRY

The Gold Plus entry fee amounts to € 12.900,00 plus 22% VAT - total € 15.738,00 (if the registration is completed by December 22, the amount due is € 12,300.00 plus 22% VAT – total € 15,006.00 VAT included) and includes:

- a) Participation in the competition after selection of the car:
- kits of documents and technical materials required;
  - Official Merchandising;
  - “Gold” Pass.
- b) Hospitality for a crew of two persons, including:
- 3 nights in two single room in Hotel 5\* Stars, with breakfast - IN 12 March 2026, OUT 15 March 2026;
  - 3 Light Lunch a buffet per person;
  - 2 Light Dinner per person;
  - Prize Ceremony.
- c) Services included in the entry:
- Possibility to purchase additional service packages.

## 6.8 REFUND OF THE ENTRY FEE FOR CREWS NOT ACCEPTED

In the case of non-acceptance and/or non-inclusion on the waiting list of a car by the organiser, the deposit will be refunded by bank transfer or accredited on the credit card, by Friday 6 March 2026.

## 6.9 WITHDRAWAL OF AN ENTERED CAR

In all cases:

- the request for withdrawal of the entry application, i.e. the entry, must be sent by e-mail to [participants@1000miglia.it](mailto:participants@1000miglia.it) with a request for acceptance by the recipient and followed by confirmation of receipt by the recipient himself. Competitors provided with certified e-mail (PEC) must send the abovementioned notice to the PEC address: [1000miglia@legalmail.it](mailto:1000miglia@legalmail.it);

- if due, the refund of the entry fees will take place within 60 (sixty) days following the announcement date of the withdrawal.

#### 6.10 REFUND OF THE ENTRY FEE IN CASE OF WITHDRAWAL OF THE ENTRY APPLICATION OR THE ACCEPTED ENTRY

Except as otherwise provided in Article 6.11 below, in the event of withdrawal, for any reason, of the entry application or the accepted entry by a Competitor, the entry fees shall be refunded only as follows:

From: opening date for entries To: closing date for entries	The fee paid as deposit by the Competitor shall be entirely refunded to the latter, net of administrative charges in the amount of Euros 150,00 plus VAT equal to 22%;
From the day following the closing date for entries To: publication of list of Competitors and cars accepted	The fee paid as a deposit by the Competitor shall be entirely refunded to the latter, net of a penalty equal to Euro 1.000,00 (VAT exempt pursuant to article 15, paragraph 1, Italian Presidential Decree 633/72);
From the day following the publication of the list of Competitors and cars accepted To: Monday 2 March 2026	The entry fee paid by the Competitor will be refunded in full to the Competitor, less a deduction for secretarial and management fees of 50% of the fee paid plus VAT at 22%;
From: Tuesday 3 March 2026	The entry fee shall not be refunded

#### 6.11 FAILURE TO PASS ADMINISTRATIVE CHECKS

In the case of failure to pass the administrative checks and/or scrutineering, the competitor will not have the right to the refund of the entry fee paid, but will retain the right to make use of the hospitality envisaged for the team and any gifts and gadgets distributed directly by the sponsors. This right shall be guaranteed only if the competitor or a crewmember with proxy signed by the competitor are present at the pre-competition administrative checks. Therefore, if Competitors or drivers authorised by the same, are not present at the pre-competition checks, they will not be entitled to the refund of the entry fee, nor will they be allowed to enjoy the hospitality provided for the crew or any benefit or facilities reserved to the participants.

#### 6.12 POSTPONEMENT OF THE EVENT DUE TO FORCE MAJEURE

Organiser shall be entitled, at any time and at its sole discretion, to postpone the Race if the health emergency caused for extraordinary and unexpected events beyond its control such as, including but not limited to, new epidemics, measures issued by the authorities, earthquakes, floods, sudden climatic changes which prevent, in whole or in part, the performance of the Race.

Any request for withdrawal shall be subject to the provisions set forth in Article 6.9 and following according to the new deadlines that will be communicated.

#### 6.13 CANCELLATION OR SUSPENSION OF THE EVENT DUE TO FORCE MAJEURE

Organiser shall be entitled, at any time and at its sole discretion, to cancel and/or suspend the Race if the health emergency caused by extraordinary and unexpected events beyond its control such as, including but not limited to, new epidemics, measures issued by the authorities, earthquakes, floods, sudden climatic changes which prevent, in whole or in part, the Race.

In case of cancellation or suspension of the Race, the Organiser shall refund the entry fees as follows:

From: opening date for entries To: closing date for entries	The fee paid as a deposit by the Competitor shall be entirely refunded to the latter;
From the day following the closing date for entries To: Friday 27 February 2026	The fee paid as a deposit by the Competitor shall be entirely refunded to the latter net of a deduction as administrative and management costs equal to 20% of the fee paid plus VAT at 22%

From: Saturday 28 February 2026	The entry fee paid by the Competitor will be refunded in full to the Competitor, less a deduction for secretarial and management fees of 50% of the fee paid plus VAT at 22%;
To: Friday 6 March 2026	
From: Saturday 7 March 2026	The entry fee shall not be refunded

In case of postponement of the race, the aforementioned time limits will be extended.

## Article 7 - GENERAL OBLIGATIONS

### 7.1. ADMINISTRATIVE CHECKS

The procedures for carrying out the administrative checks may be totally or partially dematerialised according to the regulations prepared by the ASN and national or territorial government Bodies.

Competitors and drivers must be present in person and with the accepted car, failure to do so will imply the impossibility of passing the checks and therefore of participating in the race, in the ways and means established in the programme. The Sports Inspectors and Road Traffic Police will undertake the following checks and formalities:

- a) checking of mandatory documents for competitors and drivers to be presented in original copy:
  - valid driving license, national and international;
  - sports licence of the nation of belonging or Italian daily licence, the latter for foreign crews only;
  - medical certificate;
  - valid competition car insurance;
  - competition car registration papers;
  - possible declaration of non-necessity of periodic revision of the vehicle according to the laws of the country of registration of the vehicle.
- b) hand out and apply the Personal Identification Device (CPI) described in Article 7.3 of these SR;
- c) sign, for acceptance, the check forms drawn up by the organiser and the Road Traffic Police.

After the administrative checks, competitors will receive all the documents required to present themselves for the technical checks, including any bulletin and other instructions issued by the Race Directorate. They will also receive their race numbers and Personal Identification Device (CPI).

### 7.2. PRE-ADMINISTRATIVE AND TECHNICAL CHECKS

The above documents must be uploaded by participants by Friday 20 February 2026 in their reserved area of the entry system. Failure to upload even a part of the documents referred to in Article 7.1.1 may lead to penalisation of competitors up to exclusion from the competition.

### 7.3. PERSONAL IDENTIFICATION DEVICE (CPI)

During the administrative checks, a Personal Identification Device (CPI) will be applied to each driver, in order to identify clearly the participant for the entire duration of the event.

The staff delegated by the organiser will be responsible for the application of this device and this cannot be refused by the driver.

The device cannot be ceded and cannot be removed until the end of the competition on penalty of exclusion from the race.

The exhibition of the (CPI) can be requested by Officials or by escorting Road Traffic Police, at any moment. The absence of the sticker can result in the exclusion of the crew and the car from the race.

In the case of breakage or loss of the (CPI) the driver must first notify it to the first Competitor Relations Officer he finds along the route.

**7.3.1** Only members of crews who have passed the pre-competition administrative checks can participate in the competition.

No exchanges of authorised drivers are allowed between cars in the race.

Should persons other than those who have passed the pre-competition administrative checks be found on board a competition car during the race, except for the transport of an injured person, the car and its driver will immediately be excluded from the race; this also does not exclude further penalties to be decided at the discretion of the Stewards

### **7.4 COMPETITION NUMBER STICKERS**

At the administrative checks, each competitor will receive a Sticker Kit consisting of:

- 3 round number holder stickers, with the competition number and the Organizer's advertising;
- 2 series of pre-spaced fluorescent competition numbers.

#### **7.4.1 APPLYING THE COMPETITION STICKERS TO THE CARS**

Cars must be presented for technical checks with all the kit stickers mentioned in Article 7.3 of these SR already applied, according to the following instructions:

- a) 1 round number holder sticker for each side of the competition car on the front doors (in cars with doors) or on the front sides (on cars without doors or with small doors);
- b) 1 round number holder sticker on the front bonnet of the competition car;
- c) 1 pre-spaced fluorescent number on the front windshield positioned to allow it to be seen when looking at the front part of the competition car;
- d) 1 pre-spaced fluorescent number on the rear window: should this not be possible the sticker must be applied on the rear boot in such a way as to allow it to be visible looking at the back of the competition car;

The guide layout is provided attached to these SRR, for the correct positioning of the competition numbers (Appendix 3).

Should it not be possible to apply all three of the round number holder stickers that are distributed, on the cars due to lack of space, it will be possible to apply only 2 stickers. In this case, the third sticker must be returned to the Organisation at the technical check, failure to do so could result in exclusion from the race.

### **7.5 SCRUTINEERING**

After having passed all the administrative checks, the crews must submit the cars to scrutineering, in the ways and times stated in the programme. Failure to do so will lead to the cars being excluded from the race. Checks will be as follows:

- a) check of the correct positioning of the stickers in compliance with Articles 7.4. and 7.4.1 of these SR and check of the sound and light signals suitable for travelling on the road, in addition to checking the actual possession of emergency signaling devices in the event of road accidents, such as the warning triangle and reflective vest;
- b) The cars must have one of the following valid sports documents:
  - Registro 1000 Miglia Certificate
  - ACI Historical Car Regularity Fiche;
  - HTP FIA or HTP ACI;
  - Certificate of registration in the ACI Storico Club Register;
  - FIVA-ASI Fiche Certificate of homologation or ASI identity (Targa ORO);
  - Certificate of registration in the AAVS National Historic Register;Limited to international races registered in the FIA calendar and in the ACI-Sport Calendar of national races with foreign participation (ENPEA);
  - FIA regularity historical car pass;
  - FIVA identity card.

c) placing of safety equipment as per Article 7.6 of these SR.

The configuration of the cars must comply with the criteria established by the ACI regulations, regardless of the sports document presented for admission to the races.

Foreign registered cars entered by foreign crews and without the documents listed in this article, can be admitted with a declaration of conformity to the sporting rules issued by the competitors themselves to the Organizers and countersigned by the same.

Failure to comply with even one of the above provisions is grounds for non-admission to the race, with the decision of the “Giudice Unico” or Sporting Stewards. Competitors who do not show the documents requested above will not be admitted to the competition. Likewise, cars that do not provide sufficient guarantees of suitability and safety may not be admitted.

By carrying out the administrative and technical checks, 1000 Miglia S.r.l. shall not be held liable for the actual compliance of the cars checked with the current Italian or Swiss regulations for road circulation, nor for their correct maintenance conditions; competitors and drivers shall therefore remain solely liable.

### 7.6 SAFETY EQUIPMENT

The GPS Tracker equipment supplied by the organiser must remain installed on the competition car for the entire duration of the race. The equipment must be returned to the CO/TC at the final arrival.

The device will be pre-installed during the scrutineering by company engineers (a strip of Velcro will be applied on the vehicle to fix the device) and all necessary information as well as a use manual for the device will be provided, as well as a release form for the use of data recorded on the device itself.

The “GPS Tracker” will track compliance to the route of the competition by the team and will also record the speed of the car. Recorded data will be available to the competition Directors and Stewards in order for them to take disciplinary action against the competitors who have broken the Road Safety Rules and the competition regulations, aside from any other provisions that could be taken by Police Officers who have detected an infringement of the law. Data could be made available following a request by the legal authorities.

In the case of loss or malfunction of the GPS Tracker, the competitor will notify this to the Competitor Relations Officer at every T.C. or those responsible for technical devices present at every lunch break and every arrival/start of each Leg.

In the case of withdrawal of a competitor along the route of the various Legs, the GPS Tracker will be returned to the Competitor Relations Officers or to the persons responsible for this in the Technical Support Convoy (Technical Car and Pace Car).

### 7.7 OBLIGATIONS OF COMPETITORS

Throughout the event, drivers must drive prudently and carefully, scrupulously respect the Italian Road Traffic Law and instructions given by the Clerk of the course and by Officials.

The Officials - those in Charge (Article 2 of these SR) positioned in the Technical Support convoy (teams in the Front Car, Pace Car and Technical Car), Road Traffic Police Officers will notify violations and offences of the Regulations, and the Instructions stated above.

In the case of infringements, the CoC will notify the “Giudice Unico” or Sporting Stewards who will apply the following penalties:

- first offence: 1.000 penalty points;
- second offence: 12.000 penalty points.

Depending on the seriousness of the offence, the “Giudice Unico” will apply the penalties up to exclusion from the event, even after only one offense.

In each Leg, the CoC can undertake speed checks on all the cars in the race.

The Officials along the route as well as all the cars in the Technical Support convoy (Article 2 of these SR, teams in the Front Car, Pace Car and Technical Car) and Road Traffic Police Officers will also be responsible for supervising the conduct of the competitors and their service and team vehicles, notifying the Clerk of the course of any offence but without taking any independent decisions.

Also Road Traffic Police Officers and local Police Members in the relative areas can notify the CoC of any offences by competitors and their service and team vehicles.

Driving behaviour should always be prudent for oneself, for Officials, and especially for spectators.

Each competitor is always responsible also for the behaviour of their service and team vehicles, which must necessarily strictly observe the instructions given by Officials and Marshals and must follow the route envisaged in the Road book in some parts of the competition route. Failure to comply with this provision will result in sanctions against the relevant competitor, and may even lead to expulsion from the race, at the “Giudice Unico’s” discretion.

### Article 8 – RUNNING OF THE COMPETITION

#### 8.1 START

The cars will leave one at a time, from a stationary position with the engine running, one car departing every minute. Each car, once they have been given the “go”, will have to free the Departure area as quickly as possible.

Under the control of Officials, departure may take place by pushing the car, if it fails to leave on its own.

Competitors must not stop the competition car in the control areas (between the areas signalling the Start and End areas), exception being made for the check areas where the authorisation stamp will be printed by the Officials, reversing, changing direction, opening doors and in any way hindering the other teams will lead to the application of the penalty as stated in Appendix 4 of these SR.

Drivers must keep to the Official Times stated in the Itinerary Table. No restrictions will be imposed on them as regards the use of time recording equipment. The same may be synchronized with the clock placed at the start of each Leg, without direct connection to the said clock.

Any defect in detection of times, caused by any failure or malfunction of the equipment, will result, for the said checks, in the application of the average to each competitor and/or the annulment of the checks themselves for all competitors.

The Organisers will state in the Road book, this will also be indicated on site, a straight stretch of road with measurements, used as the measured base in the preparation of the Road book, and competitors can verify this before the race.

#### 8.2 STARTING ORDER

The starting order for all the Legs will be completed taking into account the assigned race numbers (see Art. 4.4).

#### 8.3 TIME CONTROLS (CO/TC)

The purpose of the Time Control (CO/TC) is to outline the areas in which the route of the competition is divided, in order to regulate the conduct of the same and to make sure the average speed is respected.

Each competitor must be measured on the minute (e.g. for transit time 14:01 it will be possible to transit without penalty from 14:01:00 to 14:01:59).

The excesses as regards the ideal times established will determine the classification.

Penalties for delays and early arrivals at a CO/TC are those stated in Appendix 4 of these SR.

Delays and early arrivals at a CO/TC must not be caught up in the next CO/TC. Teams must leave the “check area” free for transit. They are authorised to enter this area on board their car, in the minute preceding the ideal one for transit, and remain in the area for the time strictly necessary to record the transit time.

When the time is being read, the car must be inside the time reading area. During reading operations, at least one member of the team must be on board the competition car.

The time used for the reading operation is not neutralised in any way. The reading is taken at the moment in which one member of the team hands over the Time Card to the Time-keeper.

In the case where competition cars that are late or in advance of their ideal times transit through the CO/TC in the minute pertaining to cars on time, the Time-keeper will make a note, on the Time Card of the team that is late or in advance, of the real transit time, which corresponds to the start of the next sector, giving precedence, in the marking operations, to the team with the less delay on the ideal transit time.

All the CO/TCs will be appropriately marked with signs in compliance with the examples attached to these SR (Appendix 5).

Vehicles transiting through an CO/TC in the opposite direction or a direction other than the one decided by the organiser will be excluded from the race.

### 8.4 TIME TRIALS (PC/TT)

The term PC/TT is used to refer to timed stretches of the route, between two consecutive set points, in which the drivers must comply with the times set as indicated in the TDT, the Time card, the Road book or communicated by a Bulletin.

PC/TT readings will be carried out as follows:

- a) Readings carried out with photocell: the reading equipment will be positioned at the height foreseen by the RDS of ACI Sport; a red string with a diameter of 8/12 mm will be laid in correspondence of the reading line, which identifies the line connecting the photocell and the reflecting element.
- b) Readings carried out by pressure switch.

The PC/TT will be provided in groups with variable numbers: for each group of PC/TT, a single reading system will be adopted, communicated by a Bulletin.

All time measurements will be carried out to the nearest 1/100 of a second, with no tolerance. Any deviations from the prescribed times will, as with those recorded at the CO/TC controls, contribute to determining the final ranking.

PC/TT will be undertaken with departure read at free entrance; the driver will be able to choose freely the start of the PC, nonetheless within approx. 5 seconds from the “all clear” given by the Marshals and/or the Timekeeper in charge.

Various consecutive PC/TTs will be envisaged (interconnected), where the time for passing to the final reading of the previous PC/TT will be the start time of the next PC/TT, and so forth.

All PC/TTs will be properly marked both at the start and at the end, with signs in compliance with the examples attached to these SR (Appendix 5).

In the area of the route between the yellow sign and the beige sign showing the start and end of the measuring area, cars are not allowed to park, stop or open the doors. Should any cars stop in this measuring area due to a breakdown, they must be immediately removed according to the instructions given by the competition official, on penalty of exclusion.

In the stretch of route between the yellow sign at the beginning and the beige sign at the end of the reading area, access is also forbidden to the drivers and navigators who arrive in the control area before their transit time.

Cars that will travel in a PC/TT in a different direction from that foreseen by the organizer will be excluded from the race.

In the case of absence of a reading by a competitor, or even the absence of a result by one or more PC/TT, irrespective of the reason for this, the competitor will always be assigned a time relating to the missing PC/TT as resulting from the average PC/TT actually clocked by the said competitor in the Laps where the PC/TT are missing. The request will be made at the end of the lap under consideration.

### 8.5 AVERAGE TRIALS (PM/AT)

PM/AT are those stretches of the route in which the drivers must maintain a predetermined hourly average, indicated in the TDT and in the Time Card: any difference, for early or late arrival, with respect to the ideal transit time on the secret finish lines set in these Trials will result in a penalty as provided for in Attachment 4.

The Road book will indicate the beginning and end place of each PM/AT. In the sector between the beginning and the end of the PM/AT, the average is measured in one or more points not known by the driver: the TDT will indicate the number of measurements envisaged for each AT. Up to 5 detections can be envisaged for each AT.

To allow competitors to achieve the ideal average, no timing checks will be conducted during the first kilometer of each AT.

Exit times at each AT will be recorded to the second. The total number of checks and the required average speed will be specified in the Time and Distance Table and in the Time Schedule. The road book will indicate the theoretical maximum time allowed to complete each AT. Penalties for a AT will be calculated based on the total number of seconds a competitor is early or late at each scheduled check within the AT (1 second = 1 penalty point).

#### 8.5.1 START OF AVERAGE TRIALS (PM/AT)

- a. The PM/AT start will be "free start". Each PM/AT start will consist of two positions provided in the RB, located between 40 and 100 metres apart.

The first station, manned by Marshals whose task is to facilitate and regulate the departures of the cars, will be indicated by a yellow background sign, with a waving flag. The Marshals in charge will not record the time of passage of the cars on the Competitors' Time Card.

The second station, created to allow the best precision of the timing function of the GPS-tracking equipment by detecting the transit of the car already in motion, will not be manned by Marshals and will be indicated by a red background sign with a waving flag.

- b. The competitor, once he has received an "all clear" signal from the marshals at the first station must proceed immediately, without stopping, to the second station and take the actual start for the PM/AT from **the Zero space/Zero time line** corresponding to that station. At this line, the competitor must start counting space and time in order to respect the imposed average assigned for each Trial.
- c. In order to allow the competitor to reach the ideal average, there will be no measurements during the first kilometre of each Trial.
- d. No complaints will be accepted regarding any obstacles, difficulties or hindrances that may arise in the course of the PM/AT: each competitor must overcome them using his or her own means and abilities, while respecting the Road Traffic Regulations.

### 8.6 PASSAGE CONTROLS (CT/PC)

The purpose of the Passage Controls (CT/PC) is to check the strict adherence to the established route.

The opening and closing times of the CT/PC will be notified by the Clerk of the course Bulletin. At the CT/PCs, drivers must stop the cars in order for the check stamp or "all clear" stamp to be printed in the relative area of the Time Card. The absence of this stamp will mean exclusion.

All the CT/PC areas will be properly marked with signs in compliance with the examples attached to these SR (Appendix 5).

## Coppa delle Alpi by 1000 Miglia 2026 | Supplementary Regulations

Vehicles transiting through a CT/PC area in the opposite direction or one other than the one decided by the Organiser will be excluded from the race.

### 8.7 TYRES - SNOW CHAINS

For the entire duration of the race it is mandatory to use winter tyres or M+S and to have chains aboard the cars.

### Article 9 - MAXIMUM LATENESS

A crew will be over the maximum lateness:

- if it transits through a Time Control (CO/TC) with more than 15 minutes delay.
- if it accumulates delays through various Time Controls totalling more than 30 minutes delay for every leg.

The opening and closing times of the Time Trials (PC/TT), the Average Trials (PM / AT) and of the Print Checks (CT /CP) will be notified through a Clerk of the course Bulletin.

### Article 10 - ARRIVAL

Arrival check will be St. Moritz (CH), Via Maistra and will be open from 17:15.

### Article 11 - CLASSIFICATION-PROTESTS AND APPEALS

#### 11.1 CLASSIFICATION

The following classifications will be drawn up:

- a. Overall;
- b. Category;
- c. Class;
- d. Teams;
- e. Female crews;
- f. Under 30 drivers;
- g. Average trials;
- h. Special classifications: ...TBD...

#### 11.2 PROTESTS AND APPEALS

Protests and appeals must be submitted in the manner and within the terms established by the National Sporting Regulations.

- For each protest, the security deposit is € 500,00.
- For each appeal, the security deposit is € 2.000,00.

#### 11.2.1 TERMS FOR SUBMISSION OF PROTESTS OR REQUESTS OF TIME CHECK

With the publication of the PROVISIONAL CLASSIFICATION the crews, having taken note of these times, will have 15 minutes from the time of publication of the PROVISIONAL CLASSIFICATION or from their own time of arrival, to submit, exclusively to the Clerk of the Course or the Competitors' Liaison Officer, in writing, requests for TIME VERIFICATION referring to a maximum of 1 measurement and 1 request for average application per OBSTACLE among the TT and, a maximum of 1 measurement and 1 request for average application per OBSTACLE among the AT, per race day, exclusively at the end of each day.

Further TIME VERIFICATIONS and average application requests for OBSTACLE may be requested upon payment of a security deposit of € 100,00.

## Article 12 - PRIZES

### 12.1 HONOUR PRIZES

The event will have the following honour prizes:

- for the first 5 crews of the overall classification;
- for the first 3 classified of the Category classification;
- for the first 3 crews in the classification of average trials;
- for the first Team;
- for the crew that has recorded the lowest net penalties – MVP;
- for the first classified of entirely female crews;
- for the first crew under 30;
- for the ...TBD... in the special Classification.

The event will also include the following honour prizes for the Power Stage:

- 1st crew overall – Drivers' General Classification;
- 1st crew in Category Classification;
- 1st crew in the Female Crew Classification;
- 1st crew in the Under 30 Classification;
- 1st crew overall – Modern Cars, Tribute, GT, etc.;
- 1st ranked Team;
- 1st crew in the Gentleman Classification.

The prizes of the general classification, grouping and priority drivers are not cumulative, therefore the winners of more than one classification will be awarded only the prize of the most important classification.

### 12.2 ADMISSION TO 1000 MIGLIA 2027

The following Competitors will be guaranteed acceptance at the 1000 Miglia 2027 event, subject to compliance of the car with the SR of the Competition:

- to the first entrant classified in the "Overall" Classification;
- to the first entrant classified in the "Average Trials" Classification;
- to the first entrant classified in the "Category 1" Classification;
- to the first entrant classified in the "Category 2" Classification;
- to the first entrant classified in the "Category 3" Classification;
- to the first entrant classified in the "Category 4" Classification;
- to the first entrant classified in the "Category 5" Classification;
- to the first entrant classified in the "Category 6" Classification;

The right of admission to 1000 Miglia 2027 shall not be granted to those who have already obtained it in other events organised by 1000 Miglia. Competitors who find themselves in this situation shall be transparent for the purposes of the allocation of this right.

The prizes that will give the right to participate in the 1000 Miglia 2027 edition will be given to the physical or legal subject to whom the invoice for the entry fee of the Coppa delle Alpi 2026 by 1000 Miglia Srl will be registered. The aforementioned subject's right to inform 1000 Miglia of a different subject that will acquire this right remains firm. Such request for modification must be sent via email to [participants@1000miglia.it](mailto:participants@1000miglia.it) on or before 20.03.2026. In any case, participation will be subject to the payment of the fee indicated in the Supplementary Race Regulations and will be guaranteed only to those cars which are eligible under the aforementioned Regulation.

Participation rights for the 1000 Miglia 2027 obtained in the various classifications above are not cumulative.

In the event that the winner of a Category classification is at the same time winner of the "Absolute" or "Average Trials" classification, acceptance to 1000 Miglia 2027 guaranteed for the category in question will be assigned to the first non-transparent competitor that has not already won this benefit in the two general rankings.

In the event that the winner of the "Average Trials" classification is also the winner of the "Overall" classification, the acceptance to 1000 Miglia 2027 guaranteed for the winner of the "Average Trials" will be awarded to the first non-transparent competitor who has not already won this benefit in the "Overall" classification.

## Article 13 - GENERAL RULES

### 13.1 RESPONSIBILITIES

By the very act of entering for this event, each competitor declares for themselves and their drivers, for the staff on their own service vehicles and accompanying vehicles, for their dependents and assignees:

- to recognize and accept the provisions of the National Sporting Regulations (and Sector Rules) and the present SR, committing themselves to respect and to enforce them;
- under their direct responsibility, to have their Drivers, their assistance personnel, employees and appointees sign these SRR for acceptance, which shall be strictly observed;
- to relieve the Italian Automobile Club, the ACI Sport, the ACI Brescia, the Organiser 1000 Miglia S.r.l. and all persons involved in the organisation, as well as the Automobile Clubs involved in the event, the Local Authorities involved, the Officials and the owners of the routes where the competition takes place from any liability regarding any damages to competitors, or their drivers, navigators, employees and agents, or things, or produced or caused to third parties or of objects by the competitor himself, his drivers, navigators, employees and agents.

### 13.2 DISPUTES

Competitors undertake to resolve any dispute of a patrimonial nature that may arise due to facts arising from the application and/or interpretation of these SRR and from the course of the Event by means of the sports arbitration provided for in articles 236 et seq. of the National Sporting Regulations and the ACI Sporting Justice Regulations for disputes of a sporting nature that occurred during the Event. All disputes of a technical and disciplinary nature definitively decided by the Organiser and/or its own bodies that have given rise to penalisation or exclusion from the Event rankings or to financial penalties are expressly excluded from the sporting arbitration.

### 13.3 ADVERTISING

No form of advertisement may be placed on the car, unless this is expressly provided for by the organiser, which will be announced by a special information bulletin, in compliance with the provisions of current ACI Sport legislation.

Competitors whose cars have been entered by Sponsors in "Sponsor Teams", are allowed to affix on each side of their cars a logo or writing with a maximum size of 10 cm x 20 cm or equivalent surface.

The logo or writing allowed may depict the sponsor's trademark and may appear on the cars belonging to each of the aforementioned "Sponsor Teams", and will in any case be submitted for prior authorization from the Organizer.

The number of authorised competition cars for each Sponsor, will be determined by the agreements signed between the Organiser and the Sponsor itself. To obtain the Organiser's authorisation, each interested Sponsor must submit the planned artwork and state which motor cars will be part of his "Sponsor Team" sending his request within and no later than Friday 14 February 2025, to the following address: [participants@1000miglia.it](mailto:participants@1000miglia.it).

The names of the crewmembers can be written on each of the sides of the competition cars in the maximum dimension of 10 x 40 cm per side.

A Club logo, not having advertising purpose (all or part thereof), can appear on each side of competition cars occupying a maximum space of 10 x 10 cm, per side or equivalent surface.

The original livery is tolerated as regards identification badges, even if they constitute advertising, limited however to what was originally used for that specific vehicle identified with the chassis number.

Any form of advertising that does not correspond to what is stated in this article will be removed by the Organiser and/or by Officials who will carry out checks before and during the race.

The breach of the provisions of this article will be sanctioned with 12,000 penalty. Those crews that will be found non-compliant with the provisions set forth above will be denied participation in future editions of the event. The organiser reserves the right to charge the offending crew with damages resulting from the contravention of this Article.

The participants therefore agree to assume the obligation to pay compensation for all damages suffered by the organiser and third parties in general, relieving the same from any liability, for any and all liability and/or damages resulting from the violation of the abovementioned prohibition.

### Article 14 – ATTACHEMENT

The following appendixes are an integral part of these SR:

- ATTACHEMENT 1: Itinerary Table (the definitive Itinerary Table will be communicated with the Road book);
- ATTACHEMENT 2: Maps of the route (will be communicated with the Road book);
- ATTACHEMENT 3: Positioning of competition numbers on the cars;
- ATTACHEMENT 4: Penalties and disciplinary measures;
- ATTACHEMENT 5: Signage Posters of Checks;
- ATTACHEMENT 6: Medical certificate for non-competitive sports activities

### Article 15 – COMPULSORY MOTOR VEHICLE LIABILITY INSURANCE (MVL) AND THIRD-PARTY LIABILITY INSURANCE (TPL)

Following the announcement made by ACI-Sport on 6 May 2025 regarding the awarding of the contract for compulsory insurance cover pursuant to Article 124 of the Private Insurance Code, the Organiser declares that it has taken note that the procedure has been awarded to Sara Assicurazioni S.p.A., which has guaranteed insurance coverage for all races included in the national sporting calendar from 12 May 2025 to 31 December 2025. Pending the new decision by ACI-Sport for the races included in the 2026 national sporting calendar, the Organiser 1000 MIGLIA SRL declares that it will guarantee the compulsory insurance coverage for the race in question, in compliance with the provisions of the Federation.

It is hereby specified that the Third-Party Liability insurance policy taken out by the Organiser shall be understood as a policy covering second risk liability for any damage caused by competitors to persons, property or animals during the event, excluding damage caused to the participants themselves and to the vehicles they use. All competitors therefore remain obliged to take out their own Third-Party Liability insurance policy valid for the entire duration of the event.

In any case, the policies taken out by the Organiser do not relieve Competitors and Drivers of any liability they may incur outside the scope of the insurance and any additional general and special policy conditions that may be established by the Federation.

## Coppa delle Alpi by 1000 Miglia 2026 | Supplementary Regulations

Supplementary Regulations of the classic regularity race titled for “Campionato Italiano Grandi Eventi” of 12-14 March 2026 called Coppa delle Alpi by 1000 Miglia 2026.

The Organiser declares its commitment to verify that all those who will take part in the race but who are not listed in these SR will still hold a valid sports licence issued by the Federation.

The holding of the competition is in any case subject to the issue of a permit by the competent Ministry of Transport General Directorate for Road Safety as provided for in paragraph 3 art. 9 of the new road traffic law.

These Supplementary Regulations/Organisation Permit may be withdrawn at any time in the event of a breach by the organiser of Article 56 of the National Sporting Regulations as recognised by the Federation.

The Legal Representative

signed mr. *Fulvio D'ALVIA*

The Clerk of the Course (for having read and accepted the assignment)

signed mr. *Lucio DE MORI*

For the Regional Delegation

signed mr. *Alessandro TIBILETTI*

THE SECRETARY OF ACI SPORTS BODIES

signed mr. *Marco FERRARI*

## ATTACHEMENT 1

- Itinerary Table

The official and final Itinerary Table will be available in the Road book.

ATTACHEMENT 2

- Road Map

**12-15 MARZO 2026**

**COPPA DELLE ALPI**  
*by 1000 Miglia*

AUSTRIA  
SVIZZERA

AROSA

ST. MORITZ

LIVIGNO

SVIZZERA  
ITALIA

BEVER

SAMEDAN

CELERINA/  
SCHLARIGNA

ST. MORITZ

PONTRESINA

**1ª Tappa**  
GIOVEDÌ 12  
St. Moritz → St. Moritz

**2ª Tappa**  
VENERDÌ 13  
St. Moritz → Livigno → St. Moritz

**3ª Tappa**  
SABATO 14  
St. Moritz → Arosa → St. Moritz

SCOPRI DI PIÙ  
1000miglia.it

f in @ y x

1000 MIGLIA SRL

1000 MIGLIA

ATTACHEMENT 3

- Positioning of Race Numbers on the cars

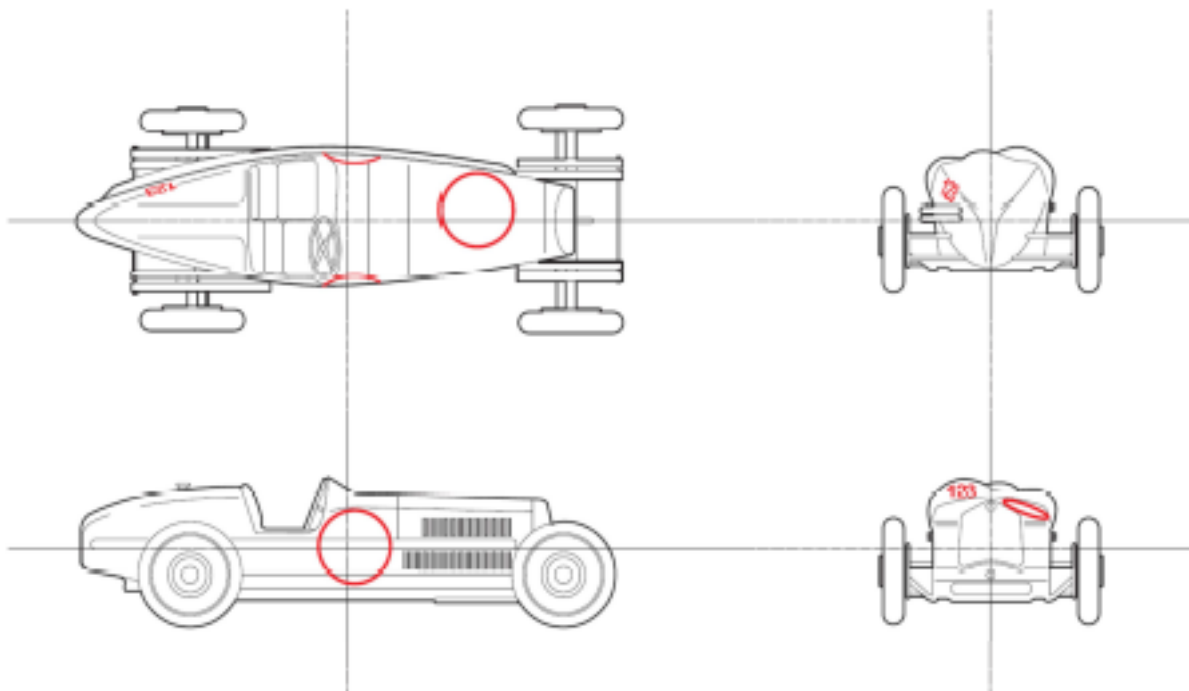
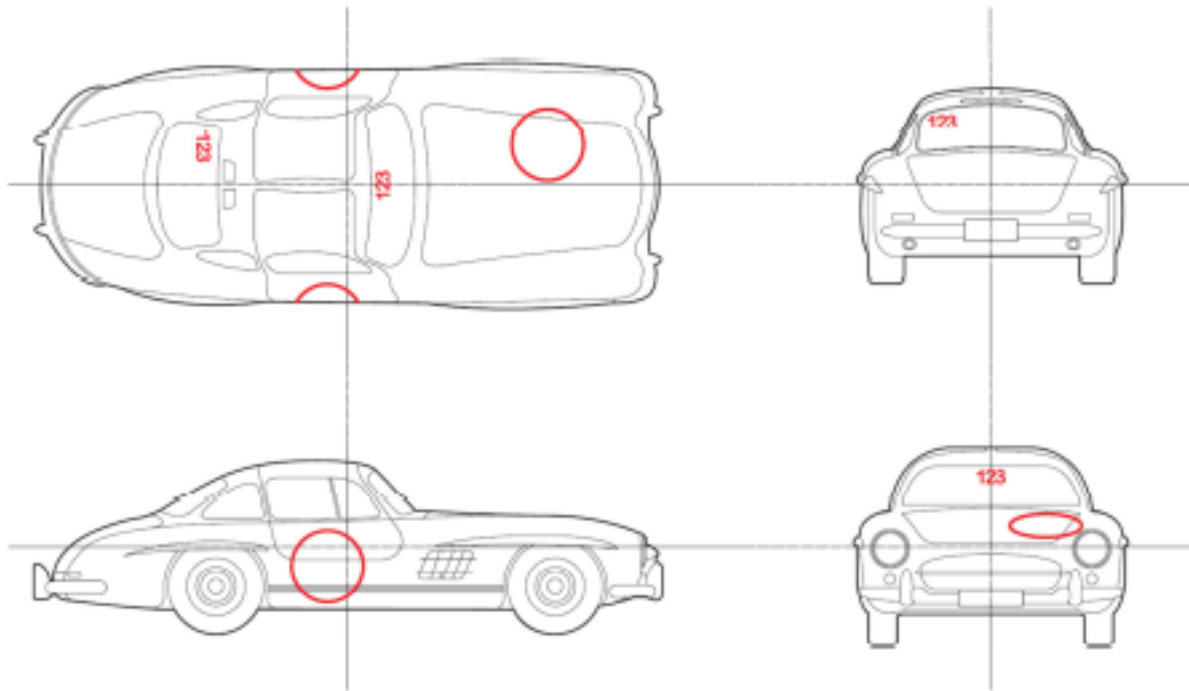

## ATTACHEMENT 4

### - Penalties and disciplinary Measures

#### Time checks (CO/TC)

- for every minute or fraction thereof early: 100 penalties
- for every minute or fraction thereof late: 100 penalties with a maximum of 300
- For each delay beyond the maximum time: exclusion<sup>(\*)</sup>

#### Time Trials (PC/TT)

- for each 1/100 of second early or late: 1 penalty with a maximum of 300

#### Average Trials (PM/AT)

- for every second early or late: 1 penalty with a maximum of 300

#### Secret Transit Checks

- for every second less over the tolerance of 20%: 10 penalty

#### Time Card

- alterations, changes or corrections not endorsed by Officials: exclusion
- Failure to record a CO/TC: exclusion
- Lack of a control stamp (CT/PC): exclusion
- Failure to return to the CO/TC of Leg arrival: exclusion

#### Other Penalties

- refusal to start at the hour and in the set order: 100 penalties
- stopping the car in the control area (stationary wheel): 100 penalties
- unauthorised access of the crew in the check area (subject to further action): 300 penalties
- missing transit or time annotation at any control point: exclusion (\*)
- unauthorized stopping in a control area: exclusion<sup>(\*)</sup>
- blocking the passage and/or damaging other crews: exclusion
- for non-sportsmanlike behaviour: from warning to exclusion
- for passage in a control area in a wrong or different direction: exclusion
- for infringement of the Highway Code: up to exclusion
- for irregularities in documents during checks: no admission
- failure to comply with the checking times: up to exclusion
- for delay in departure more than 15 minutes: no admission
- allowing a person other than a crew member to drive the car: exclusion
- lack of a competition number or competition license plate: fine
- lack of two or all of the competition numbers: exclusion
- for failure to notify withdrawal to the Race Management: fine
- for failure to comply with the provisions relating to stopwatch synchronization: up to exclusion
- for non-prudent behaviour of a crew member, or assistants or team car: up to exclusion
- for leaning out of a moving car: up to exclusion
- for any specious or unjustified request to verify times: up to exclusion
- Failure to comply with the orders of Officials and Marshals: up to exclusion
- article 7.5 - first offense: 1.000 penalties
- article 7.5 - second offense: 12.000 penalties
- infringements of the rules on advertising on cars in the race: 12.000 penalties

#### <sup>(\*)</sup> Re-admission

Crews that exceed the maximum time and crews that have not passed through one or more checks (CO, PC, PM, CT) are automatically re-admitted at the start of the next leg. If they are re-admitted, they will receive a penalty of 12 000 points.

ATTACHEMENT 5

- Control signs

CARTELLI DEI CONTROLLI - CONTROL SIGNS

<b>CO / TC*</b>	INIZIO ZONA CONTROLLO • CONTROL AREA START	CONTROLLO • CONTROL	FINE ZONA CONTROLLO • CONTROL AREA END
	GIALLO/YELLOW mt 25 circa - approx.	ROSSO/RED mt 25 circa - approx.	BEIGE mt 25 circa - approx.
<b>CT / PC**</b>			
INIZIO ZONA CONTROLLO • CONTROL AREA START	CONTROLLO • CONTROL	INIZIO ZONA CONTROLLO • CONTROL AREA START	FINE ZONA CONTROLLO • CONTROL AREA END
GIALLO/YELLOW mt 25 circa - approx.	ROSSO/RED mt 25 circa - approx.	GIALLO/YELLOW mt 25 circa - approx.	BEIGE mt 25 circa - approx.

<b>PC***</b> SINGOLE O CONCATENATE LUNGHEZZA INFERIORE / UGUALE A 300 MT.	INIZIO ZONA CONTROLLO • CONTROL AREA START	CONTROLLO • CONTROL	FINE / INIZIO PC • END / START TT	INIZIO ZONA CONTROLLO • CONTROL AREA START	CONTROLLO • CONTROL	FINE PC • END TT
	GIALLO/YELLOW mt 25 circa - approx.	ROSSO/RED lunghezza inferiore/uguale - length inferior/equal to 300mt.	ROSSO/RED lunghezza inferiore/uguale - length inferior/equal to 300mt.	GIALLO/YELLOW mt 25 circa - approx.	ROSSO/RED mt 25 circa - approx.	BEIGE mt 25 circa - approx.
<b>TT***</b> SINGLE OR CONNECTED LENGTH INFERIOR / EQUAL TO 300 MT.	INIZIO ZONA CONTROLLO • CONTROL AREA START	CONTROLLO • CONTROL	FINE / INIZIO PC • END / START TT	INIZIO ZONA CONTROLLO • CONTROL AREA START	CONTROLLO • CONTROL	FINE PC • END TT
	GIALLO/YELLOW mt 25 circa - approx.	ROSSO/RED lunghezza inferiore/uguale - length inferior/equal to 300mt.	ROSSO/RED lunghezza inferiore/uguale - length inferior/equal to 300mt.	GIALLO/YELLOW mt 25 circa - approx.	ROSSO/RED mt 25 circa - approx.	BEIGE mt 25 circa - approx.
<b>PC***</b> SINGOLE O CONCATENATE LUNGHEZZA SUPERIORE A 300 MT.	INIZIO ZONA CONTROLLO • CONTROL AREA START	CONTROLLO • CONTROL	FINE / INIZIO PC • END / START TT	INIZIO ZONA CONTROLLO • CONTROL AREA START	CONTROLLO • CONTROL	FINE PC • END TT
	GIALLO/YELLOW mt 25 circa - approx.	ROSSO/RED lunghezza inferiore/uguale - length inferior/equal to 300mt.	ROSSO/RED lunghezza inferiore/uguale - length inferior/equal to 300mt.	GIALLO/YELLOW mt 25 circa - approx.	ROSSO/RED mt 25 circa - approx.	BEIGE mt 25 circa - approx.
<b>TT***</b> SINGLE OR CONNECTED LENGTH SUPERIOR TO 300 MT.	INIZIO ZONA CONTROLLO • CONTROL AREA START	CONTROLLO • CONTROL	FINE / INIZIO PC • END / START TT	INIZIO ZONA CONTROLLO • CONTROL AREA START	CONTROLLO • CONTROL	FINE PC • END TT
	GIALLO/YELLOW mt 25 circa - approx.	ROSSO/RED lunghezza inferiore/uguale - length inferior/equal to 300mt.	ROSSO/RED lunghezza inferiore/uguale - length inferior/equal to 300mt.	GIALLO/YELLOW mt 25 circa - approx.	ROSSO/RED mt 25 circa - approx.	BEIGE mt 25 circa - approx.

<b>PM</b> PROVA DI MEDIA CON UNO O PIU' CONTROLLI SEGRETI	INIZIO ZONA CONTROLLO • CONTROL AREA START	CONTROLLO • CONTROL	INIZIO PM • START AT	CONTROLLO • CONTROL	LIMITE DELL'ESTENSIONE DELLA PM - LIMIT AT EXTENTION
	GIALLO/YELLOW mt 25 circa - approx.	ROSSO/RED	ROSSO/RED	ROSSO/RED	ROAD BOOK SYMBOL
<b>AT</b> AVERAGE TEST WITH ONE OR MORE SECRET CONTROLS	INIZIO ZONA CONTROLLO • CONTROL AREA START	CONTROLLO • CONTROL	INIZIO PM • START AT	CONTROLLO • CONTROL	LIMITE DELL'ESTENSIONE DELLA PM - LIMIT AT EXTENTION
	GIALLO/YELLOW mt 25 circa - approx.	ROSSO/RED	ROSSO/RED	ROSSO/RED	ROAD BOOK SYMBOL

estensione della prova di media / extention of average test

**\*Ai Controlli Orari NON SEGUITI da Start Prova Cronometrata**

Le vetture sono autorizzate ad entrare nella zona di controllo (tra il cartello giallo e quello rosso di controllo) nel minuto che precede il loro minuto teorico di transito (solo se la zona è già stata liberata dalle vetture che precedono) oppure nel loro minuto teorico di transito e devono consegnare la tabella di marcia al cronometrista, per l'annotazione dell'orario di transito. I membri dell'equipaggio sono autorizzati a rimanere a bordo della vettura.

**\*\*Ai Controlli Timbro**

I membri dell'equipaggio devono rimanere a bordo della vettura e consegnare al commissario la tabella di marcia, per l'apposizione del timbro, senza iscrizione dell'orario di transito; la sosta nella zona deve essere limitata all'operazione di timbratura.

**\*\*\*Nelle Prove Cronometrate**

Tra il cartello giallo di inizio ed il cartello beige di fine zona controllo è vietato l'arresto (fermo vettura/fermo ruote) e la sosta della vettura.

**\*At the Time Controls NOT FOLLOWED by Start Time Trials**

The cars are authorized to enter the control area (between the yellow and red control sign) in the minute preceding their theoretical transit minute (only if the area has already been freed from the cars ahead) or during their theoretical transit minute and must hand in the time card to the timekeeper, in order for him to note down the transit time. Crew members are allowed to remain on board the car.

**\*\*During the Time Trials**

Between the yellow sign at the beginning and the beige sign at the end of the control area, it is forbidden to stop (vehicle stopped/wheels stopped) and park the car.

**\*\*\*At the Stamp Controls**

The crew members must remain on board the car and hand in the time card to the Marshal, where he will put the stamp, without inscription of the transit time; parking in the area must be limited only to the stamping operation.

ATTACHEMENT 6

- Medical certificate for non-competitive sports activities

Legge n°125,art.4,comma 10 septis e Decreto Ministero della Salute dell'08 agosto 2014

**Certificato di idoneità alla pratica di attività sportiva di tipo non agonistico**

Sig.ra / Sig.....

Nata/o a ..... il .....

residente a.....

Il soggetto, sulla base della visita medica da me effettuata,dei valori pressione arteriosa rilevati,nonché del referto del tracciato ECG eseguito in data ....., non presenta controindicazioni in atto alla pratica di attività sportiva non agonistica.

Il presente certificato ha validità annuale dalla data del rilascio.

Luogo.....

data.....

il Medico

.....

timbro con codice identificativo e firma

**Certificate of Fitness for non-competitive sporting activities**

Mr/Ms.....

Born in ..... on.....

Resident in .....

The individual, on the basis of a medical examination carried out by myself, including arterial blood pressure readings and ECG, carried out on....., does not present any current contraindications to non-competitive sporting activities.

This certificate is valid for one year from the date of issue.

Place..... Date.....

The Doctor

.....

Stamp with identification code and signature